



Design Modification of an Indigenous Extruder

O. O. Koyenikan^{1*}, O. J. Olukunle² and A. P. Olalusi²

¹*Department of Agricultural and Bio-Environmental Engineering, The Federal Polytechnic, Ado, Ado-Ekiti, Nigeria.*

²*Department of Agricultural and Environmental Engineering, The Federal University of Technology, Akure, Nigeria.*

Authors' contributions

This work was carried out in collaboration among all authors. Author OOK designed the study, performed the statistical analysis, wrote the protocol and the first manuscript. Authors OJO and APO managed the analyses of the study and literature searches. All authors read and approved the final manuscript.

Article Information

DOI: 10.9734/JERR/2019/v4i216899

Editor(s):

(1) Dr. Tian- Quan Yun Professor, School of Civil Engineering and Transportation, South China University of Technology, China.

Reviewers:

(1) Adejugbe, Idowu Tolulope, Engineering Materials Development Institute, Ondo State, Nigeria.

(2) Azuddin Mamat, University of Malaya, Kuala Lumpur, Malaysia.

Complete Peer review History: <http://www.sdiarticle3.com/review-history/46938>

Original Research Article

Received 23 December 2018

Accepted 21 February 2019

Published 20 March 2019

ABSTRACT

This research involved the design and modification of an existing fish feed extruder which was subjected to evaluation in order to produce floatable fish feeds. It was observed that the temperature of the extruded feed was on the average of 70°C with moisture content of 25% wet basis. The modifications incorporated into the existing extruder included the water pump, sprockets and chain, circuit box containing essential electrical components and temperature sensors. The volume of hopper, weight of hopper, diameter of the screw auger, power required to drive the screw auger, volume of the extruding barrel, forces and weight acting on the chain, speed for driving the larger and smaller sprocket, length of the sprocket chain, weight of screw for each revolution, total load acting on the screw, torsional moment of the screw and diameter of shaft were designed. Another modification was the incorporation of a system that could raise the barrel's internal temperature for five different temperatures between 90°C and 130°C. The functional efficiencies of the existing and modified extruder were 56.52 and 91.30% and their throughput capacities were 0.53 and 1.24 kg/hr respectively.

*Corresponding author: Email: koyenikanomolola@gmail.com;

Keywords: Extruder; extrusion, functional efficiency; throughput capacity and temperature.

1. INTRODUCTION

Extrusion is a process by which moistened, expansible, starch and/or proteinous materials are plasticized and cooked in a tube by a combination of moisture, pressure, temperature and mechanical shear. Extrusion process is a combined unit operations which includes feeding, mixing, cooking, kneading, shearing, shaping and forming. Extruder barrel consists of three main zones [1]. Extrusion of feed is a combination of heat; shearing and pressure build up in the presence of water. The superiority of extrusion over conventional steam conditioning and ring die pelleting include: better formulation flexibility, higher versatility in physical size and shape, greater water stability and physical integrity, and greater fat absorption capacity. The principal advantages of extrusion over traditional food and feed production methods, includes the following; adaptability, product characteristics, energy efficiency, low cost, high productivity, automated control as well as high product quality. Extrusion process enhances the feed efficiency and prolongs the shelf life of the feed [2]. The major advantages of pelletization of foods and feeds using extrusion are improved digestibility due to gelatinization of starch, ingredient separation prevention during handling and transit and the physical integrity and chemical composition of the pellets which are maintained for extended periods during storage, handling, and transportation [3]. During extrusion, raw material is cooked and plasticized in the presence of moisture, temperature, and mechanical shear resulting in texturized novel products [4]. In the last five decades, food extrusion has developed from a simple pressing and forming technology into a sophisticated cooking process, and has replaced many conventional food processing technologies.

An extruder is a machine which shapes materials under pressure by forcing it through a specially designed opening. According to Harper, [5] and Serrano, [6] a food extruder consists of a flighted Archimedes screw which rotates in a tightly fitting cylindrical barrel. Raw ingredients are pre-ground and blended before being placed in the feeding system of the extruder screw. The action of the flights on the screw pushes the food products forward and in so doing, mix the constituents into a viscous dough-like mass.

In the feed manufacturing technology, extruders are used for different purposes, and are

classified based on their shear, heat generation and numbers of screws [7].

2. MATERIALS AND METHODS

2.1 Brief Description of the Existing Single Screw Extruder

The existing single screw extruder consisted of a steel barrel, housing the extrusion worm, a hopper located at one end of the machine while a discharge end was equipped with a nozzle shaped die whose sizes were varied at the other end. The machine was powered by a reduction geared motor and power was transmitted via belt and pulley to the extruder worm. Two vents are located at the compression and discharge zones of the extrusion barrel through which extrusion temperature can be monitored during the experiments. The worm was designed as autogenic i.e. such that it could generate its heat through friction between materials and the continually reducing screw depth. Due to the complexity of the existing extruder and poor quality of feed extruded from it, the extruder was modified to produce floatable fish feed that is hygienic for human consumption.

2.2 Evaluation of the Existing Single Screw Extruder

Before the modification of the extruder was done, the existing one was evaluated and observations were made. A locally compounded feed mixture (unextruded) with low density formulation was obtained, compounded and tested with the existing extruder with moisture content of 25% wet basis. The throughput capacity and functional efficiency of the extruder were determined.

2.2.1 Determination of throughput capacity of the existing single screw extruder

Based on the fact that researchers extrude feed of weight between 0.21 kg and 0.52 kg per unit time to determine the throughput capacity and functional efficiencies of extruder, 0.46 kg mass of thoroughly mixed unextruded feed materials was weighed with an electronic weighing balance of model JA-5000 and fed into the hopper while the total time taken for the extrudate to completely exit from the die of the extruder was taken with the aid of a stop watch. This was used

to calculate for the throughput capacity of the extruder according to Akinfiresoye et al., [9].

$$C_t = \frac{Q}{T_t} \quad (1)$$

Where, C_t is the Throughput Capacity of the extruder (kg/hr), Q is the Quantity of extrudate exiting the extruder (Output) (kg) and T_t is the Total time taken for the extrudate to exit the extruder (hr).

2.2.2 Determination of functional efficiency of the existing extruder

Also, 0.46 kg mass of thoroughly mixed unextruded feed materials was fed into the hopper while the total weight of the extrudate that finally came out at the die of the extruder was taken. This was used to calculate for the functional efficiency of the extruder. It was calculated according to Akinfiresoye et al., [9]

$$\eta_f = \frac{Q}{I} \times 100 \quad (2)$$

Where

η_f is the Functional Efficiency of the extruder (%), I is the total mass of extrudate fed into the extruder /Input (kg) and Q is the total mass of extrudate exited from the extruder/ Output (kg).

2.3 Description of the Modified Extruder

The extruder consist of three switches: one for the electric motor which is a three-phase gear motor it supplies power to the system, another to the temperature controller switch which controls the temperature of the extruding barrel and can also pre-set the working temperature of the barrel and lastly, there is the switch which controls the on and off switch of both the heater and water pump. When the switches are switched on from the main switch board, the three-phase line light would glow. The drive is connected via a sprocket and chain that supplies power to the main driven shaft/screw.

2.4 Special Design Features of the Modified Extruder

These included the followings:

- a. **Water pump:** The water pump was incorporated into the modified extruder to ensure the adequate circulation of hot water round the extrusion area of the

barrel for effective heat transfer via the water jacket.

- b. **Sprockets and chain:** The sprocket and chain replaced the belt and pulley system in order to reduce slippage and power loss.
- c. **Circuit box:** A circuit box containing essential electrical components for the regulation of the temperature of the boiling chamber and the extrusion process was incorporated into the modified extruder.
- d. **Temperature sensors:** It was included in the modified extruder in order to automate and regulate the temperature of the system.
- e. **Electric motor:** The variable reduction gear electric motor used in the existing extruder was replaced with a 300 rpm electric motor according to Fayose *et al.*, [10] when she selected the 300 rpm electric motor as opined by Fellows [11] who suggested that, for typical screw speeds of between 150 and 600 rpm, speeds should be selected for food extruders. The Gearbox is made high-precision gear hobbing machines and comprehensive quality control to ensure that it provides highly accurate gear engagement, smooth running and minimum noise.

2.5 Design Considerations and Analyses of the Modified Extruder

The existing extruder modified in this study was guided by challenges associated with it. Other pertinent considerations were basic engineering principles and innovations. Hence, factors that governed the modification and subsequent selection of materials for the extruder were (i) the incorporation of a system that could raise the barrel's internal temperature for five different temperatures of 90°C, 100°C, 110°C, 120°C and 130°C, (ii) incorporation of 3 mm and 4.5 mm die (iii) incorporation of water pump (iv) hygiene, (v) ease of cleaning, (vi) low labor and maintenance cost, (vi) availability of raw materials for construction, (vii) safety, (viii) costs, (ix) ease of automation, (x) thermal compatibility, (xi) simplicity of fabrication and dismantling, (xii) resistance to corrosion, rust and wear, (xi) rigidity, strength and reliability.

2.5.1 Determination of angle of inclination of the hopper

The angle of inclination of the hopper was determined according to Fasimirin, [12]

$$\Theta = 10^\circ + \alpha \quad (3)$$

Where, Θ is the Angle of inclination and α is the Angle of repose, Angle of repose (α) for fish feed by (El-sayed et al., 2014) is 27° i.e. $\alpha = 27^\circ$, $\Theta = 10^\circ + 27^\circ$. The Angle of inclination, Θ is 37°

2.5.2 Determination of hopper volume

$$\text{Volume of hopper} = \frac{1}{3} \times h (A_1 + A_2 + \sqrt{A_1 \times A_2}) \quad (4)$$

Where,

V is the Volume of hopper, h is the Height of hopper, A_1 is the Area of upper base and A_2 is the Area of lower base. The Volume of the hopper is $3.8 \times 10^{-3} \text{m}^3$

2.5.3 Determination of weight of fish feed hopper

This is calculated using equation 3 according to Akinfiresoye et al., [9].

$$\text{Weight of fish feed} = M_h \times g \quad (5)$$

Where,

M_h = Mass of fish feed in the hopper and g = Acceleration due to gravity. The weight of fish feed that can be accommodated into the hopper at once is 33.6N.

2.5.4 Determination of screw auger diameter

This is also calculated using equation 4 according to Akinfiresoye et al., [9].

$$D^2 = \frac{4Q}{60\pi S n \rho c} \quad (6)$$

Where, Q is the Capacity of the extruder, S is the Screw pitch, n is the Speed of convey, ρ is the unit density of the material (Feed) and c is the loading factor depending on the inclined angle to the horizontal $D = 0.106 \text{m}$ i.e., the Diameter of Auger is 106 mm.

2.5.5 Determination of power required to drive the screw auger

This is calculated using equation 5 according to Fayose et al., [10].

$$P = \frac{QL}{367} (W_o + \sin \beta) \frac{1}{\eta} \quad (7)$$

Where, P is the Power to drive the screw auger, Q is the Capacity of the auger, L is the Length of the Auger and η is the Extruder's Efficiency. W_o is constant which is 4 for slow-flowing abrasive material Odesola, (2016) = 5 hp. Based on the calculated value, 5 hp electric motor is selected with speed of 300 rpm according to Fayose et al., [10].



Plate 1. The existing fish feed extruder

Source: [8]



Plate 2. Pictorial view of the modified extruder

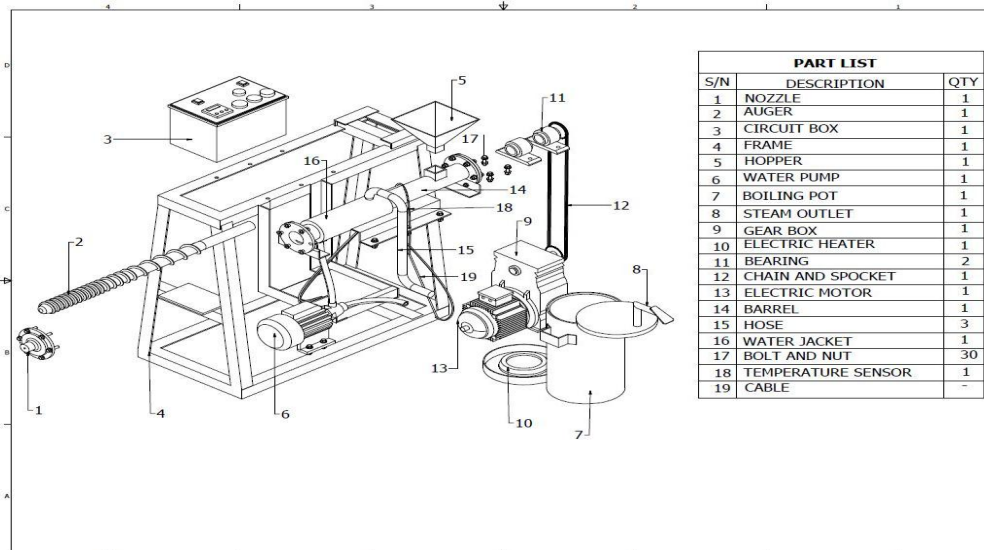

Fig. 1. Exploded view of the modified fish feed extruder

2.5.6 Determination of volume of extruding barrel

According to Akinfiresoye et al., [9],

Volume of cylinder,

$$V_b = \pi r^2 \times L$$

Where,

$$V_b = \frac{\pi d^2}{4} \times L$$

Where,

D is the Diameter of the barrel, L is the Length of the barrel and V_b is the Volume of barrel. The volume of the barrel is $6.6 \times 10^{-3} \text{ m}^3$.

(8)

2.5.7 Determination of forces and speed acting on the chain

According to Fayose et al., [10],

$$F_r = \frac{P}{V_c} \tag{9}$$

Where, F_r is the Tangential Force (N), P is the Power transmitted (watts) and V_c is the Speed of chain.

$$V = \frac{TPN}{60} \tag{10}$$

Where,

T is the Number of teeth in the Sprocket, P is the Pitch of chain in meters, N is the Speed of the Sprocket, V is the Speed of chain, $V_1 = V_2 = 0.375$ m/s and $F_r = 10,666.67$ N.

2.5.8 Determination of chain length

This is calculated from equation 9 and 10 according to [13].

$$L = K.P \tag{11}$$

$$K = \frac{T_1 + T_2}{2} + \frac{2x}{P} + \left[\frac{T_2 - T_1}{2\pi} \right]^2 \frac{P}{x} \tag{12}$$

Where,

T_1 is the number of teeth on the smaller sprocket, T_2 is the number of teeth on the larger sprocket, P is the pitch of the chain, x is the centre of distance, K is the number of chain links Length of chain, L is 1.5 m, $F_c = T_1 = 0.082$ N, $F_s = T_2 = 5.12$ N and

$$T_1 + T_2 = F_c + F_s \tag{13}$$

Akinfiresoye et al., [9]

Total weight acting on the chain is 5.20 N

2.5.9 Determination of weight of screw

This is also calculated using equation 12 according to Akinfiresoye et al., [9].

$$\text{Weight of Screw for one revolution} = M_s \times g \tag{14}$$

Where, M_s is the Mass of the Screw and g is the acceleration due to gravity. The Weight of Screw for one revolution is 2N. So for the Screw of 13 revolutions, total weight is 26N

2.5.10 Determination of total load acting on the screw

According to Odesola, [14],

$$L = L_1 + L_2 \tag{15}$$

Where,

L is the total load applied, L_1 is the weight of sprocket and the total force acting on the chain and L_2 is the Weight of material fed into the hopper at once and the weight of the screw and

$$L_1 = W_{sp} + T_f \tag{16}$$

Where, W_{sp} is the Weight of Sprocket, T_f is the Total force acting on the chain

$$L_2 = W_m + W_{sc} \tag{17}$$

Where, W_m is the weight of material fed into the hopper at once and W_{sc} is the weight of Screw

L_1 is 6.77 N

From equation 14, L_2 is 59.6N,

$$L = L_1 + L_2 = 6.77N + 59.6N = 66.37N.$$

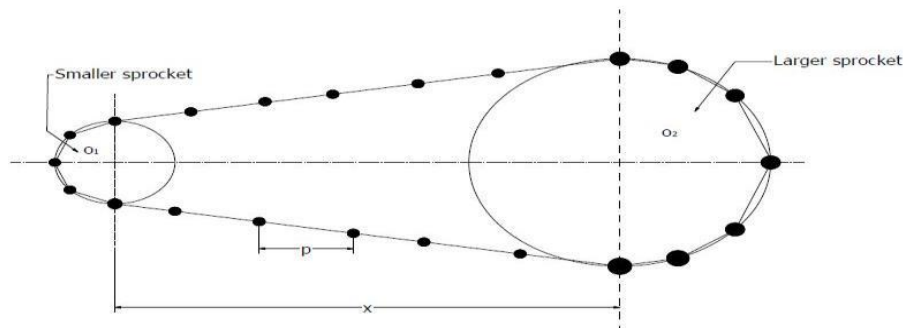

Fig. 2. Schematic drawing of the chain

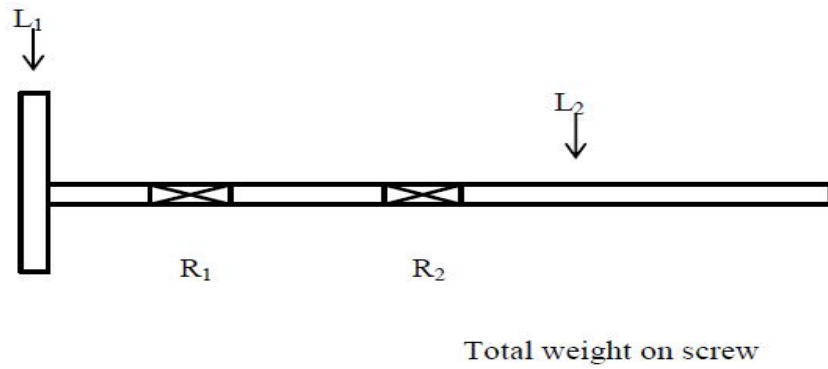

Fig. 3. Total weight on Screw

2.5.11 Determination of torsional moment of screw

$$M_t = F_t R \tag{18}$$

Where, F_t is the Tangential Force at the pitch radius and R is the Pitch Radius. The torsional moment of the screw is 400 Nm.

2.5.12 Determination of bending moment

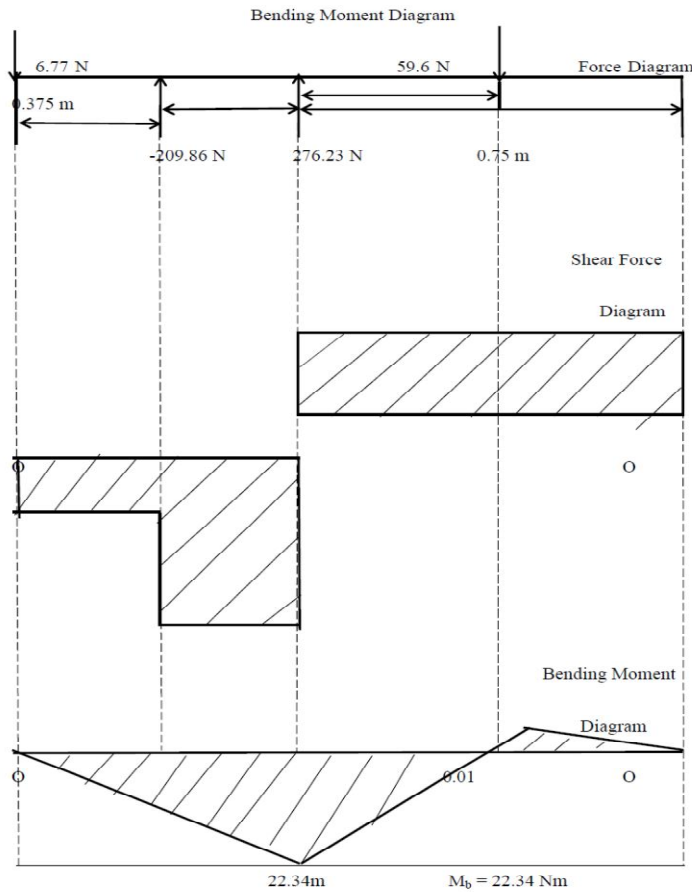

Fig. 4. Bending moment diagram

Starting from point A

$$\begin{aligned}
 A &= -6.77 \times 0 = 0 \text{ Nm} \\
 B &= -6.77 \times 0.1 + (-209.86 \times 0) = -0.677 \text{ Nm} \\
 C &= -6.77 \times 0.2 + (-209.86 \times 0.1) + (276.23 \times 0) = -22.34 \text{ Nm} \\
 D &= -6.77 \times 0.575 + (-209.86 \times 0.475) + (276.23 \times 0.375) - (59.6 \times 0) = +0.01 \text{ Nm} \\
 E &= -6.77 \times 0.95 + (-209.86 \times 0.85) + (276.23 \times 0.75) - (59.6 \times 0.375) = 0.0 \text{ Nm}
 \end{aligned}$$

2.5.13 Determination of shear force

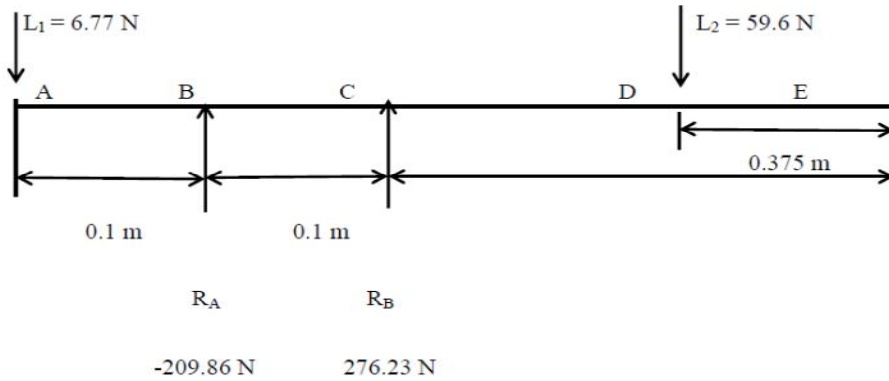

Fig. 4. Force diagram

Starting from point A
At point A

$$\begin{aligned}
 A &= -6.77 \text{ N} \\
 B &= -6.77 \text{ N} - 209.86 \text{ N} = -216.63 \text{ N} \\
 C &= -216.63 \text{ N} + 276.23 \text{ N} = 59.6 \text{ N} \\
 D &= 59.6 \text{ N} - 59.6 \text{ N} = 0 \text{ N}
 \end{aligned}$$

2.5.14 Determination of shaft diameter

According to Okunola, [15],

$$d^3 = \frac{16}{\pi \delta_s} \sqrt{(K_b M_b)^2 + (K_t M_t)^2} \quad (19)$$

Where, d is the Diameter of shaft ($40 \times 10^6 \text{ N/m}^2$), δ_s is the Allowable shear stress, K_b is the Combined shock and fatigue factor for bending, K_t is the Combined shock and fatigue factor for twisting or torsion, M_t is the Maximum twisting moment and M_b is the Maximum bending moment. The Shaft diameter is 37 mm.

2.5.15 Determination of power required to pump water

$$P_w = \rho g Q H \quad (20)$$

Where, ρ is the density of water (kg/m^3), g is the acceleration due to gravity (m/s^2), Q is the flow rate of water (m^3/s) and H is the total pumping head (m). The power required to pump water is 0.55 W (0.00055 KW).

2.6 Mode of Operation of the Modified Extruder

To commence the experiment, all the switches were switched on, to make sure that the extruder runs freely without any hitch. On the extruder, is the hopper with a speed control plate which is used to control the quantity of feed that enters the extrusion chamber or serves as flow rate. The control plate is opened to the desired position. When the extruder is loaded with the formulated feed, the working temperatures of the heater was pre-set. The drive for both the water pump and the heater was switched on, which was allowed to run. When the pump is switched on, the heated water flows in counter direction to the flow of the feed in the barrel. This helps to maintain the temperature of the extrudate while extrusion continues until the extruded feed comes out from the die.

Before the machine was powered, the boiling chamber was filled with cold water and the heater was switched on to boil the water. Thereafter, the machine was then powered hence; the water pump was triggered into action for continuous flow of water. The feed material after mixing with little quantity of water, was passed through the hopper into the machine which was powered by the electric motor in which power was transmitted via chain and sprocket mechanism. Hot water flows in a cycle

from the boiling chamber into the water jacket through the water pump down into the extrusion chamber. This continues until, the barrel become heated up. The friction action of the stabilizing material between the extruder screw and the barrel wall increases the temperature in the chamber.

2.7 Experimentation Process of the Modified Extruder

A constant feed per formulation of 0.46 kg as weighed using a laboratory weighing balance was fed per time into the extrusion chamber. The moisture contents of the extrudates were also tested for, for each temperature; by mixing the feed materials with appropriate quantity of water. The moisture feed were extruded at a pre-set of 90 °C. During extrusion, when the material temperature reaches the desired temperature such as 90°C etc. as pre-setted by the temperature control panel and the sensor placed into the boiling chamber, the heater triggers off thus making the water to cool gradually but allows the simultaneous temperature build-up from inside the barrel to remain constant at the desired temperature to which it has been pre-set. Once the temperature of the barrel/extrusion chamber reaches its peak, it begins to decrease automatically, until it triggers on again to the desired temperature. This process continues in a cycle and keeps the machine temperature constant at that desired temperature to which it is set. The feed blend was passed through the extruder and ejected through the die. The results obtained were used to calculate for the Functional Efficiency and Throughput Capacity of the Modified extruder.

3. RESULTS AND DISCUSSION

3.1 Results

Table 1 shows the functional efficiency and throughput capacity of the existing and modified extruder.

Table 1. Functional efficiency and throughput capacity of the existing and modified extruder

Parameters	Existing extruder	Modified extruder
Initial mass (kg)	0.46	0.46
Time (s)	1760	1220
Output/Final mass (kg)	0.26	0.42
Efficiency (%)	56.52	91.30
Throughput Capacity (Kg/hr)	0.53	1.24

3.2 Discussions

The existing extruder had several components incorporated into it such as the fan and radiator which only helped in controlling the temperature of water circulating in the extrusion chamber but did not help in setting it at a desired temperature. They also occupied more space thus, it was therefore necessary to remove them so that the modified extruder occupied lesser space. Due to the reduction in the total space occupied, it has made the portability and mobility of the machine easier and less stressful. Some components were also repositioned or replaced such as the boiling chamber, the shafts, electric motor, belt and pulley as well as some bearing. All these adjustments have helped in the reduction of the total space. Table 1 shows that the functional efficiencies of the existing and modified extruder were 56.52 and 91.30% and their throughput capacities were 0.53 and 1.24kg/hr respectively. This implies that the modified extruder was more efficient and had lesser resident time for extrusion when compared to the existing extruder.

3.2.1 Analyses for the modified extruder

The results obtained for the design of the modification of the extruder is as follows: the volume of hopper was $3.8 \times 10^{-3} \text{m}^3$, the weight of hopper was 33.6 N, the diameter of the screw auger was 0.106 m, the power required to drive the screw auger was 5 hp, the volume of the extruding barrel was $6.6 \times 10^{-3} \text{m}^3$, the forces and weight acting on the chain were 5.12N & 5.20N respectively, the speed for driving the larger and smaller sprocket was 0.375m/s, the length of the sprocket chain was 1.5m, the weight of screw for each revolution was 2N, the total load acting on the screw was 66.37N, the torsional moment of the screw was 400 Nm and the diameter of shaft was 0.037 m.

4. CONCLUSIONS AND RECOMMENDATIONS

An existing single screw fish feed extruder was evaluated and it was observed that the temperature of the extruded feed was on the average of 70 °C with moisture content of 25% wet basis. It was also observed, that the functional efficiency of the existing and modified extruder was 56.52 and 91.30% and their throughput capacities were 0.53 and 1.24kg/hr respectively. Based on the evaluation and observation of the existing extruder and its modification, we therefore recommend that it should be used for commercial use since the functional efficiency and throughput capacity of the modified extruder was 91.30% and 1.24 respectively with lesser resident time for extrusion when compared to the existing extruder. Also, feed producers should carry out routine proximate analyses when a new batch of fish feed ingredients is procured.

COMPETING INTERESTS

Authors have declared that no competing interests exist.

REFERENCES

1. Anyanwu DC. Fishing and fish production in the tropics; an overview. Cel-Bez & Co., Owerri, Imo State, Nigeria. 2005;143.
2. Yogendra S. Effect of starch source, screw configuration and steam injection on physical quality and color development of extruded fish feed. Department of Aquacultural and Animal Sciences. Master Thesis 30 Credits 2011. Norwegian university of life sciences. 2011;1-2.
3. Riaz MN. Extruders in Food Applications (pp. 1-2, 19, 27, 82-85). Lancaster, PA, USA: Technomic Publishing Co, Inc; 2000.
4. Jaya ST. A case study on Maximizing Aqua Feed Pellet Properties using Response surface methodology and Genetic Algorithm. British Journal of Applied Science & Technology. 2013;3(3): 567-585. SCIENCE DOMAIN *international* Available:www.sciencedomain.org
5. Harper JM. The food extruder. In Extrusion of foods; Ed.; CRC Press, Inc.: Boca Raton, Fl. 1981;7-19.
6. Serrano X. The extrusion-cooking processing animal feeding. Nutritional Implication In: Morand-Fehr P. (Ed.). Feed manufacturing in Southern Europe: New Challenges. Zaragoza: CIHEAM, (Cahiers Options Mediterraneennes; n.26). 1997; 107-114.
7. Sorensen M, Nguyen, Storebakken T, Øvreland M. Starch source, screw configuration and injection of steam into the barrel affect the physical quality of extruded fish feed. Aquaculture Research. 2010;41:419-432.
8. Olatunde V. Improved Design and Performance Evaluation of Fish Feed Extruder. Unpublished Thesis. The Federal University of Technology Akure. Ondo State; 2015.
9. Akinfiresoye WA, Olukunle OJ, Oyerinde AS, Olutayo LA, Edun BM. Optimization of the Development of Wood Plastic Composite Extruder, Department of Agricultural and Bio-Environmental Engineering Technology, Rufus Giwa Polytechnic, Owo, Ondo State, Nigeria, Department of Agricultural and Environmental Engineering Technology, Federal University of Technology, Akure, Ondo State Nigeria and Department of Mechanical Engineering Technology, Ogun State Institute of Technology, Igbesa, Ogun State. International Journal of Research – GRANTHAALAYAH. 2018; 6(3):ISSN- 2350-0530(O); ISSN- 2394-3629(P). DOI: 10.5281/zenodo.1218525 Available:[Http://www.granthaalayah.com](http://www.granthaalayah.com)
10. Fayose FT, Agboola S, Ogunlowo AS, Agbetoye LAS. The design, fabrication and preliminary testing of an indigenous single screw extruder. Department of Agricultural and Bioresources Engineering, University of Oye, Ikole-Ekiti Campus, Oye Ekiti, Nigeria. Journal of Engineering Science and Technology. 2017;12(10):2585-2598.
11. Fellows PJ. Food processing technology: Principles and practice. England: Woodhead Publishers Limited; 2003.
12. Fasimirin J. Development of melon shelling and cleaning machine. Department of Agricultural Engineering, School of Engineering and Engineering Technology, Federal University of Technology Akure, Ondo State, Nigeria; 2014.
13. Khurmi RS, Gupta JK. A Text Book of machine design. Eurasia Publishing House (PVT.) Ltd. Ram nagar, new delhi-110 055, pp 759-775 International. 2005;8:19–29.

14. Odesola IF, Kazeem RA, Ehumadu NC. Design and Construction of a Fish Feed Extruder. International Journal of Scientific & Engineering Research. 2016;7:1378.
ISSN 2229-5518 IJSER © 2016
Available:<http://www.ijser.org>
15. Okunola OI. Development of waste plastic washing and shredding machine. Department of Agricultural Engineering, School of Engineering and Engineering Technology, Federal University of Technology Akure, Ondo State, Nigeria; 2016.

© 2019 Koyenikan et al.; This is an Open Access article distributed under the terms of the Creative Commons Attribution License (<http://creativecommons.org/licenses/by/4.0>), which permits unrestricted use, distribution, and reproduction in any medium, provided the original work is properly cited.

Peer-review history:
The peer review history for this paper can be accessed here:
<http://www.sdiarticle3.com/review-history/46938>