



# Production and Characterization of Silica from Rice Husk: An Updated Review

Md. Tariqul Islam <sup>a,b</sup>, Md. Faruk Hossen <sup>a\*</sup>, Md. Ali Asraf <sup>a</sup>,  
Md. Kudrat-E-Zahan <sup>a</sup> and C. M. Zakaria <sup>a</sup>

<sup>a</sup> Department of Chemistry, University of Rajshahi, Rajshahi-6205, Bangladesh.  
<sup>b</sup> Bangladesh Council of Scientific and Industrial Research (BCSIR), Bangladesh.

## Authors' contributions

*This work was carried out in collaboration among all authors. All authors read and approved the final manuscript.*

## Article Information

DOI: 10.9734/AJOCS/2024/v14i2296

## Open Peer Review History:

This journal follows the Advanced Open Peer Review policy. Identity of the Reviewers, Editor(s) and additional Reviewers, peer review comments, different versions of the manuscript, comments of the editors, etc are available here: <https://www.sdiarticle5.com/review-history/113971>

Review Article

**Received: 08/01/2024**  
**Accepted: 12/03/2024**  
**Published: 16/03/2024**

## ABSTRACT

Rice is regarded as one of the most valuable sources which is consumed by almost fifty percent of the world's population. Rice husk ash is a by-product substance obtained from the rice husk by thermal and chemical treatment. The non-crystalline nature of silica content in rice husk, which is converted to crystalline silica such as quartz, tridymite, and cristobalite on thermal treatment. It has been an important material which impacts not only enhances the betterment of industrialization but also protects the environment from pollution. The produced silica was characterized by various analyses such as Fourier transform infrared spectroscopy (FTIR), X-ray diffraction analysis (XRD), Scanning electron microscope (SEM), Transmission electron microscope (TEM), and Thermal analysis. This review is given attention to integrating and investigating processing, properties, characterization, reactivity, and application of rice husk (RH) and rice husk silica (RHS).

\*Corresponding author: E-mail: fhossen.chem@yahoo.com;

**Keywords:** Rice husk; silica; production; characterization; application; rice husk; fibrous material; organic materials; silica gels; chemical compounds; fertilizers.

## 1. INTRODUCTION

Rice husk is an agricultural waste residue and a fibrous material extensively available in rice-producing countries. They are composite compounds of silica with organic materials and natural capsules that form on rice grains during the process of growing [1,2]. Rice husk is an extensive by-product of rice processing industries and is used as fuel and animal feed in rural areas and used as animal feed [3,4]. The RH is the commercially usable raw material for obtaining silica gels and powders [5]. RH is a fascinating source of decent levels of high quality and quantity of silica which has found much use in various purposes of applications such as adsorbent, [6] zeolites [7-11], aerogels [12], etc. The formation of RHA from RH and a high amount of hydrated amorphous SiO<sub>2</sub> and less amount of carbon is obtained. The components which are depending on the rice variety, particle size, furnace type, burning condition, climate change, soil types, fertilizers, and geographical area [13]. The amorphous and crystalline silica has a great impact on the industry. Amorphous silica is used as a raw material to obtain plastics, cosmetics, coatings, rubber, optics, refractories, and electronics. In the glass and ceramic industry, crystalline silica is applied heavily [14]. At a lower temperature on rice husks, the amorphous nature of silica such as β-quartz (573-870°C) was obtained. At higher temperatures, the amorphous silica converted to crystalline silica such as cristobalite (1470-1710°C) and tridymite (870-1470°C) [15-17]. In presence of a polar solvent, the shape of silica particles was well-ordered and spherical but when two different polar solvents were used, then no remarkable difference in the size of the silica particle [18]. Silica (SiO<sub>2</sub>) is one of the valuable inorganic multiuse chemical compounds. It can exist in gel, crystalline, and amorphous forms. It is the most abundant material on the earth's crust [19]. The nature of amorphous silica is extremely permeable in its structure. The reactivity of the rice husk silica depends on the structure but not on the size of the particle. The reactivity of fume silica is lower than porous amorphous silica [20]. The amorphous silica formed as opal and semiprecious stone in the rice husk, but the crystalline silica existed in three phases such as quartz, tridymite, and cristobalite [21]. The crystalline structure of silica was obtained by

thermal treatment [22]. The chemical structure of silica is shown in Fig. 1.

In the countryside area of Bangladesh, RH is utilized as a source of energy for the boiling process. It is not an expensive source of energy for those purposes. When RH is burnt for generation, then the combustion product is not only a waste material but also provides an environmental problem. The main goal of the review is to extract silica from RHA and investigate its properties. This process plays an important role in producing silica powder at a very low cost and reducing disposal as well as pollution to protect the environment.

## 2. METHODS FOR PRODUCTION OF SILICA

### 2.1 Thermal Method

In order to produce silica from agronomy-based waste residue, thermal treatment is necessary. Rice husk is transferred into RHA by the thermal treatment process. The RHA was used as the starting material for the extraction of silica [23]. To produce RHA, various thermal treatments such as muffle/electric furnaces, cyclonic furnaces, fixed bed furnaces, inclined step-grate furnaces, rotary kilns, and Fluidized bed reactors were used [24]. Azat et al. have extracted silica materials from RH by thermal heating treatment. The RH was heated in a muffle furnace at 600°C for 4 hours [25]. It was reported that the high crystalline silica was produced from RH in a muffle furnace at 900°C for 6 hours [26]. Ghorbani et al. have synthesized amorphous silica from RH using acid leaching treatment in a muffle furnace at 600°C [27]. Della et al. have extracted amorphous silica with a heating rate of 10°C/min in an electric furnace at different temperatures such as 400,500,600 or 700C for 1,3 or 6 hours [28]. The different methods carried out for the production of silica are shown in Table 1.

### 2.2 Chemical Method

In the chemical method, a strong acid was used on RH to eliminate organics and metallic impurities. Strong acids such as hydrochloric acid (HCl), Sulfuric acid (H<sub>2</sub>SO<sub>4</sub>), and nitric acid (HNO<sub>3</sub>) were utilized in the leaching treatment [37].

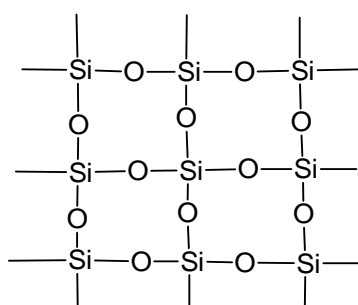

**Fig. 1. Structure of Silica**

**Table 1. Different methods for the production of silica**

Serial No.	Methodology	Description	References
1	Muffle furnace	Amorphous silica is produced from RHA with thermal treatment at 500°C for 5 hr. and crystalline silica at 1100-1200°C.	[29]
2	Fluidized bed	A high energy content of silica obtained in rice husk ash by rapid analytical method and dense phase zone was greater than the precipitated form of silica.	[30]
3	Muffle furnace	Various size of crystalline silica was observed at different temperature 400-1200°C.	[31]
4	Electric furnace	Silica powder produced from the rice husk at 700°C at a heating rate of 5C°/min	[32]
5	Muffle furnace	The Spherical size of amorphous silica consists of Si and O with a large surface area from the rice husk at the temperature of 700°C.	[33]
6	Muffle stove	The amorphous nature of silica with high purity and surface area by the acid leaching at 600°C for 3 hours.	[34]
7	Fluidized bed	The high-quality amorphous silica was extracted from rice husk ash under different temperatures with velocity.	[35]

The drawbacks of thermal treatment of RH to produce high-quality silica [36].

1. A huge amount of energy was consumed.
2. The production rate of rice husks silica was lower.
3. Longer reaction time.
4. Batch-like process.
5. Sometimes explosions occur.

Chandrasekhar et al. successfully produced silica from RHA using organic acid treatments such as acetic, oxalic, and inorganic acids such as hydrochloric and nitric acids of different concentrations [38]. Chun et al. extracted mesoporous silica from RH. In this procedure, the impurities of RH were removed using deionized water and dried in an oven. The dried RH was mixed with H<sub>2</sub>SO<sub>4</sub>(72%) for 1 hour. After adding water to the solution, the concentration of sulfuric acid converted to 4% at 121°C for 1 hour, and the separating sulfuric acid from the solution was washed with water and heated at 80°C for

24 hr. The white silica was obtained during RHA was burned at 900°C [39]. An et al. derived silica powders from RH using hydrochloric acid (HCl). RHA was mixed with HCl in thermostat for a half an hour and washed with distilled water until acid-free solution and then it was dried at 120°C [40]. Adam et al. produced silica from rice husks using nitric acid by the sol-gel technique [41]. Carmona et al. derived silica from RH by acid leaching process. In the procedure, the amount of RH was dissolved in an acid solution, then the solution was mixed with distilled water at high pressure and temperature for 1 hours [42]. Since

Song et al. synthesized nano-silica from rice husk ash by the alkaline extraction method. In this procedure, about 300-900 mg RHA was added in 9 ml of 1.5 M sodium hydroxide, NaOH in a beaker at 90°C for 1 hours. The RHA was transformed into sodium silicate solution in NaOH then the solution was heated and diluted until 1M concentration. Sodium silicate solution was titrated with 1M hydrochloric acid (HCl) at 7.0 pH with constant stirring and the solution mixture was enveloped and placed in an oven at 70°C to stage for 1–7 days then silica nanoparticle was obtained [43]. Panasenko et al. produced silica from RHA using 1M NaOH by alkaline extraction technique (Scheme 1). In the initial step RH was converted into RHA, Then Sodium hydroxide solution was mixed with RHA and boiled for 5 hours in a round-bottom flask equipped with a condenser in a hemispherical heating mantle to dissolve the silica and to obtain a sodium silicate solution [44, 45]. In the second step, the silica was precipitated when an acid solution was added to dissolve the sodium silicate solution [46]. Table 2 shows the composition of rice husk varies with geological location.

The acid-leaching process was very hazardous to the environment, and humans and caused materials corrosion. The chemical method has been an economical problem due to utilizing of

expansive materials and disposal treatment of used strong acids [49].

### 3. PROPERTIES AND CHARACTERIZATION

The development of many advanced instruments in the field of material characterization has facilitated structural studies of RH and its thermally produced products. Nowadays, many researchers all over the world have utilized sophisticated techniques such as IR, FTIR, XRD, SEM, TEM, TGA, DTA, and DSC [50].

#### 3.1 Fourier Transform Infrared (FTIR) Analysis of Silica

The RHA with powder samples of interest has interacted with infrared spectroscopic analysis. These analyses were executed with the Fourier Transform Infrared Spectrometer in the range 400-4000  $\text{cm}^{-1}$ . The considerable amount of silica particles was mixed properly with KBr and continued to the sample cup of the diffuse Reflectance Accessory for scanning in the spectrum. Ananth et al. were used to identify functional groups in RHA and RHS by FTIR spectroscopic instrument. The range of isolated and separate silanol groups of Si-OH was indicated in the interval of 3670-3000  $\text{cm}^{-1}$  and the intensity peaks of Si-O-Si in between 1200-1050  $\text{cm}^{-1}$  [51]. An et al. reported that

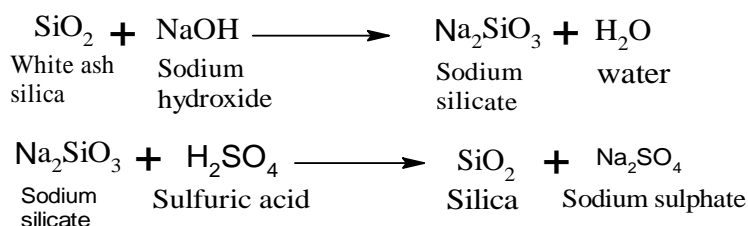

**Scheme 1. Reaction for the Production of Silica from Rice Husk Ash**

**Table 2. The composition of rice husks varies with geological location**

Component	Rice husk ash %	Rice husk ash %	Rice husk ash%
SiO <sub>2</sub>	94.60	76.66	81.4
CaO	0.40	1.07	1.60
Al <sub>2</sub> O <sub>3</sub>	0.30	0.07	1.80
Fe <sub>2</sub> O <sub>3</sub>	0.30	0.04	1.01
Na <sub>2</sub> O	0.20	0.29	0.16
K <sub>2</sub> O	1.30	2.47	2.35
MnO	-	0.13	-
TiO <sub>2</sub>	-	0.01	-
MgO	0.30	0.65	2.25
P <sub>2</sub> O <sub>3</sub>	-	0.86	5.26
Others	2.60	17.75	4.17
References	[47]	[3]	[48]

FTIR spectroscopic instrument is employed to recognize functional groups of produced silica. The appeared intensity peaks of stretching and bending mode of adsorbed water were at 3416 and 1639  $\text{cm}^{-1}$  respectively. The obtaining peaks of different modes of  $\text{SiO}_2$  such as asymmetric, symmetric, and bending were 1093, 788, and 466  $\text{cm}^{-1}$  respectively [52]. Vlaev et al. observed different functional groups exist in RHA such as silanol Si-OH and siloxane Si-O-Si. The IR spectra of RH gave typical bonds of Si-O-Si stretching (very strong at 1096  $\text{cm}^{-1}$  and strong at 798  $\text{cm}^{-1}$ ) and bending vibrations (very strong at 466  $\text{cm}^{-1}$ ). The intensity bands Si-OH vibrations at 3437 and 1633  $\text{cm}^{-1}$  respectively [53]. Liu et al. characterized silica and chemical groups were determined by FTIR spectrometer. The appearing absorbance peak of asymmetry stretching vibration (Si-O-Si) was 1105  $\text{cm}^{-1}$  and symmetry stretching and bending vibration were at 797  $\text{cm}^{-1}$  and 472  $\text{cm}^{-1}$  respectively. The absorbance peak of silanol groups at 3363  $\text{cm}^{-1}$  and 951  $\text{cm}^{-1}$  for asymmetry stretching vibration and bending vibration respectively [54]. Table 3 shows the FTIR data for rice husk ash obtained from different sources.

### 3.2 X-Ray Diffraction (XRD) Analysis of Silica

X-ray diffraction analysis is used to identify whether the obtained silica was crystalline or amorphous at a definite temperature [61].

Crystalline growth during heat treatment and silica ash production from RH and it has been studied by Ibrahim and Helmy using X-ray diffraction (XRD). It was shown that the nuclei of disordered cristobalite were present in the silica-containing ash. The X-ray diffraction pattern of RHS was determined using Bruker D8 Discovery X-ray Diffractometer by Rohani Abu Bakar et al. The maximum intensity of silica has appeared at  $2\theta = 22^\circ$  which indicates the amorphous nature of silica below temperature 900°C. After increasing temperature, amorphous silica converted to the crystallization phase [62]. Saceda et al. reported that the crystallinity of RHS was observed by XRD pattern. At the higher temperature, the observed peaks of  $2\theta$  values of 20.9, 21.9, 26.6, 31.4, and 36.0° which indicate silica in crystalline form, and the interplanar spacing  $d$  values of 4.06, 3.35, 2.85, and 2.49 by Bragg's equation. The  $d$  values data indicated that These were tridymite and cristobalite reflections [10]. Qudratun et al. reported that the amorphous and crystalline nature of silica was produced. The observed peaks of XRD  $2\theta$  angle of 22° with an intensity that stipulated for amorphous at 800°C and crystalline at 900°C [63,64]. Haslina et al. characterized silica and compared it to commercial fumed silica. The intensity peaks of RHA and fumed silica of  $2\theta$  values at 15-30°C that indicating amorphous in nature [65]. The crystallinity of rice husk silica at different temperatures shown in Table 4.

**Table 3. FTIR Data for Rice Husk Ash from Different Sources**

Component	Silanol OH/ $\text{cm}^{-1}$	Siloxane bonds (Si-O-Si)/ $\text{cm}^{-1}$	References
Rice husk ash	3460	1039	[54]
	3426	1092	[55]
	3493	1091	[56]
	3431	937	[57]
	3429	1101	[58]
	3400	997	[59]
	3400	850-950	[60]

**Table 4. Crystallinity of Rice Husk Silica at Different Temperatures**

Component	$2\theta$ (theta)/°	Temperature/°C	Crystal's characteristics	References
Rice husk silica	22	900	Crystalline	[65]
	36.541	700	Amorphous	[66]
	16-72	1000 – 1400	Crystalline	[67]
	18-30	850-900	Amorphous	[68]
	10-90	800	Amorphous	[69]
	22	700	Amorphous	[70]

### 3.3 Scanning Electron Microscopy (SEM)

Scanning electron microscopy (SEM) is a virtual technology that is used worldwide in the field of research. It's regarded as an operative method in the analysis of organic and inorganic materials and those materials converted nanometer(nm) to micrometer( $\mu\text{m}$ ) scale [71]. Krishnarao et al. obtained a morphological change of RHA as a consequence of heat. During crystallization at  $1200^{\circ}\text{C}$ , the size of RHA converted from 50 to  $20\ \mu\text{m}$  and smooth surface area [72]. Ghassan Abood Habeeb et al. reported that RH samples were examined by scanning electron microscopy and obtained high surface area with multilayered, angular, microporous, and grey colors. When RHA was performed with the LA machine then the particle size minimized from 63.8 to  $11.5\ \mu\text{m}$  for a grinding time of 90 to 360 minutes respectively [73]. The porous cellular structure and irregularly shaped particles of RHS originated with SEM micrographs observed by Le Anh-Tuan Bui et al. They reported that the particle size of RHA could be converted to an 11-12  $\mu\text{m}$  range in diameter [74,79]. Rosario Madrid et al. synthesized amorphous silica with a porous and high surface area which was characterized by SEM micrographs. The particle size of the RHA sample was observed at  $30\ \mu\text{m}$  [75]. R.M. Mohamed et al. synthesized zeolite NaY and NaP from RH. The uniform size of amorphous crystals NaY was produced through a two-step route and the particle size was  $4\ \mu\text{m}$  which was characterized by SEM analysis. After crystallization for 48h, the NaY crystal was transformed to NaP. The main drawback of SEM analysis was that it was not justified the shape of NaP crystals due to most of the crystals having been cracked through the center [9]. Tzong-Horng Liou et al. characterized nano-silica and the particle size was changed with pH which was determined by scanning electron microscopy. At pH 3, the size of an irregular-shaped silica powder of 50-60  $\mu\text{m}$  converted to nano size and spherical silica with 5-10 nm [76,86]. To perform different treatments on RH, Lara Janaína Fernandes et al. identified silica from RHA samples by scanning electron microscopy (SEM). The observed shape of the silica particle was irregular and size below  $10\ \mu\text{m}$ . The chemical composition of silica was altered by different pretreatments, but the shape and size were not changed [77]. The shape and size of nano-silica particles were characterized by SEM and the shape of silica particles was influenced by the solvent. When there was no solvent/nonpolar used, then those were irregular,

and with a polar solvent, the particles were spherical and well-ordered [78].

### 3.4 Transmission Electron Microscopy (TEM)

Transmission electron microscopes (TEM) are versatile techniques in which a particle beam of electrons is transmitted through an ultra-thin specimen. When the interaction of the electron with the specimen, then produced a highly magnified image. Hello et al. synthesized solid ammonium sulfate using RHA and a rod-like structure was attained by the TEM micrographs [79], also the determination of length is about various millimeters (mm) and the range of diameter of micro rods is  $0.1\ \mu\text{m}$  to  $0.26\ \mu\text{m}$  [80]. Sheeraz et al. synthesized different silica particles from RH and analyzed them by the TEM micrographs. The accumulated and irregular shape of silica particles was obtained without ethanol and the Spherical and scattered particles appeared in the presence of ethanol. When the amount of ethanol was increasing then more scattered particles were observed and upgraded the formation of Si-OH and Si-O-Si more spherical [78].

### 3.5 Thermal Analysis

Nassar et al. produced functionalized silica from RHA by sol-gel method and analyzed silica components by thermal analysis. In this procedure, at the temperature range of  $60-80^{\circ}\text{C}$ , the weight of the sample decreased, and then a weight-loss water molecule was absorbed on the silica surface. In the range of  $250-460^{\circ}\text{C}$ , the decomposition of organic part and -OH groups on the surface. At above  $400^{\circ}\text{C}$  temperature, there was no loss of weight of the sample. In differential thermal analysis, two exothermic peaks were obtained the first peak was observed between  $250^{\circ}\text{C}$  and  $280^{\circ}\text{C}$ , with a maximum of  $270^{\circ}\text{C}$ , and the second peak was observed between  $350^{\circ}\text{C}$  and  $460^{\circ}\text{C}$ , with a maximum of  $380^{\circ}\text{C}$ . This data indicated that a non-crystalline polymer was obtained [81]. Ali et al. characterized silica particles of RHA. In the thermal analysis of RHS, 6.8% weight loss was observed in the thermogravimetric analysis. The organic materials such as carbon and unburnt elements were separated at around  $200$  to  $650^{\circ}\text{C}$ . The highest weight loss has occurred at  $300^{\circ}\text{C}$ . This result was assigned to the presence of ceramic oxide [82]. Jembere et al. synthesized silica powder from RHA and determined the thermal stability of RHA and RHS by Differential

Scanning calorimetry (DSC). The data reflected that the major peaks of the melting point of RHA and RHS were 462.31°C and 499.7°C respectively. During the extraction, the melting point of RHS was reduced due to the presence of impurities. The observation of two enthalpies of RHS was changed at 215°C and 250°C due to the loss of organic materials from the sample [83]. Yanping Zou and Tiankui Yang analyzed acid-leached and untreated RH by Thermogravimetric process (TG). In the analysis, the temperature range at 50-150°C, and the moisture was removed from RH. The volatile matter was removed from RH at the temperature of 240-360°C. The thermal stability of acid leaching of RH was smaller than unleached RH [84]. Tadjarodi et al. characterized nano-porous silica by thermal analysis such as TGA, DTA, and DSC. In the TG curve, the first weight loss indicated that the water molecule was removed up to 100°C temperature and the second weight loss indicated that a polycondensation reaction occurred and organic groups were removed also due to oxidation reaction. In DTA curves there are two exothermic peaks were obtained at 370°C and 680°C respectively [85].

#### 4. COLOR

Rice husk is converted into RHA by the thermal and chemical treatment process. When introducing heat to RH, various colors of ash were obtained. The color change was associated with the total combustion process. The structure of RHS was converted into different phases. The

white color of the ash was obtained due to the complete oxidation process. The white color of the ash indicated the amorphous nature of silica. A strong interaction between potassium and silica produced potassium polyciliate which was conjugated to carbon obtaining grey color ash. The grey color of the ash indicated the transition state of silica. During the acid leaching process, acid was treated with potassium polyciliate, Then the potassium ion as well as the grey color was removed from the ash. At higher temperatures, the transition phase of silica was converted to crystalline silica such as cristobalite and tridymite with pink color [86-89].

#### 5. APPLICATION

Rice husk silica has been playing an important role in almost every field of life even a century after its discovery. In the earth's crust, silica is the amplest oxide yet despite this abundance, silica is predominantly made by synthetic means for its use in technological applications and it is one of the most relevant inorganic various chemical compounds [89,90]. Nowadays, it has been dealing with nano silica has expanded significantly and includes various aspects in industries, catalysis [91,92], pharmaceuticals, electronics, dental materials, ceramics [93], optical element production, chromatography [94], vegetable oil refining [95], and others [96]. The extracted silica materials are fascinating for biomedical, industrial, and environmental applications [4].

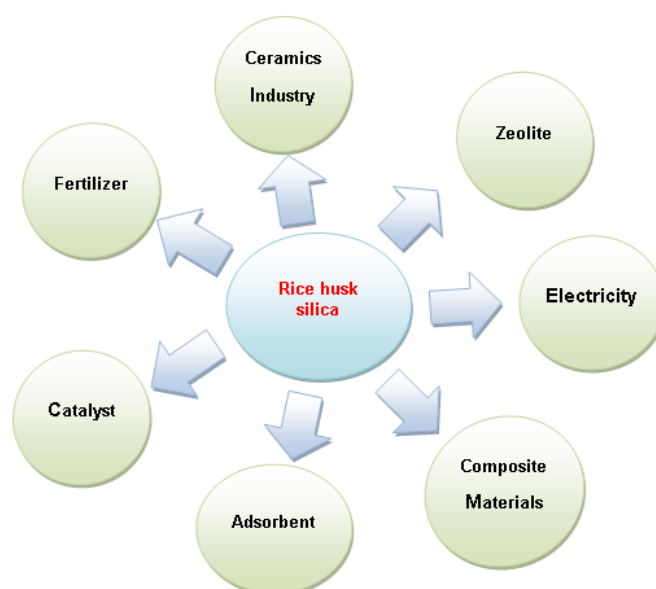
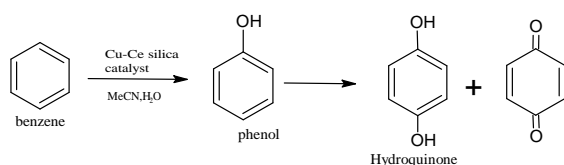

Fig. 2. Application of Rice husk silica



The precipitated silica was applied in many industries such as cosmetics, tire industry, reinforcing agents in rubber, thickening agents in paints, and anti-caking agents in the food industry [97]. Several silicate-based substances such as zeolite, silicon carbide, silicon alloy, and soluble silicates from RH are applicable for different purposes [98]. RHA is a potential agro-waste residue that is used as fertilizer [99], and amorphous silica was utilized by plants and could not be absorbed as a crystalline form of silica [100]. RH as raw materials to produce electricity systematically to enhance local income and protect the environment [102-104]. In the presence of  $H_2O_2$ , the oxidation of benzene in acetonitrile solvent produces hydroquinone and 1,4-benzoquinone. In this reaction, the Cu-Ce silica plays an important role as the catalyst [93]. The oxidation of benzene with Cu-Ce silica catalyst is presented in Scheme 2.



**Scheme 2. Oxidation of Benzene with Cu-Ce Silica Catalyst**

Rice husk silica is used as composites and semiconductor materials [104,105]. Silicon-carbide-reinforced composites have greater advantages than ceramic matrix composites [106]. Rice husk silica is a very pozzolanic characteristic that is used in cement industry. The cost-effective and high-grade cement was obtained due to the existence of RHA in cement [107,108].

#### 4. CONCLUSION

Now a day, the development of new products, waste management, and by-products has been playing a great role in interest. RH is one of the prospective agro residues which can be utilized as very cheap raw materials. It is regarded as a sustainable silica source to produce high quantities of amorphous and crystalline silica. In industrial applications, silica and silica materials are highly essential. The containing high amount of silica makes it an important raw material used in various industries like molecular sieve, zeolite, electronics, cement, absorbent, polymer industries, etc. The review highlighted that thermal and chemical treatment for production of silica and techniques such as FTIR, XRD, SEM,

TEM, TGA, DTA, and DSC are used to characterize silica.

#### ACKNOWLEDGEMENTS

The authors would like to acknowledge the financial support in this research work provided by the Faculty of Science, Rajshahi University, Rajshahi-6205, Bangladesh.

#### COMPETING INTERESTS

Authors have declared that no competing interests exist.

#### REFERENCES

1. Yalçın N, Sevinç V. Studies on silica obtained from rice husk. *Ceramic International*. 2001; 27: 219-224.
2. Chandrasekhar S, Pramada PN, Majeed J. Effect of calcination temperature and heating rate on the optical properties and reactivity of rice husk ash. *Journal of Materials Science*. 2006;41(23):7926–33. DOI:10.1007/s10853-006-0859-0
3. Kordatos K, Gavela S, Ntziouni A, Pistiolas KN, Kyritsi A, Kasselouri-Rigopoulou V. Synthesis of highly siliceous ZSM-5 zeolite using silica from rice husk ash. *Microporous and Mesoporous Materials*. 2008;115(1–2):189–96. DOI: 10.1016/j.micromeso.2007.12.032.
4. Farooquea KN, Zamana M, Halimb E, Islama S, Hossaina M, Mollahb YA, Mahmoodb AJ, Characterization and Utilization of Rice Husk Ash (RHA) from Rice Mill of BD. *Bangladesh journal of scientific and industrial research*. 2009;44(2):157-162.
5. Kalapathy U, Proctor A, Shultz J. An improved method for production of silica from rice hull ash. *Bioresource Technology*. 2002;85:285–289.
6. Dutta Gupta A, Bhadauria V, Singh H. Silica derived from rice husk ash and loaded with iron oxide for As(III) adsorption from water: Experimental and modelling studies. *International Journal of Environmental Analytical Chemistry*; 2021. DOI:10.1080/03067319.2021.1943373.
7. Azizi SN, Yousefpour M. Synthesis of zeolites NaA and analcime using rice husk ash as silica source without using organic template. *Journal of Materials Science*. 2010;45(20):5692–5697. DOI:10.1007/s10853-010-4637-7



8. Mohamed RM, Mkhaliid IA, Barakat MA. Rice husk ash as a renewable source for the production of zeolite NaY and its characterization. *Arabian Journal of Chemistry*. 2015;8(1):48–53.
9. Mohamed RM, Mkhaliid IA, Barakat MA. Rice husk ash as a renewable source for the production of zeolite NaY and its characterization. *Arabian Journal of Chemistry*. 2015;8(1):48–53.
10. Saceda JJF, De Leon RL, Rintramee K, Prayoonpokarach S, Wittayakun J. properties of silica from rice husk and rice husk ash and their utilization for zeolite y synthesis. *Industrial and Engineering Chemistry*. 2001;17:182–185. DOI:10.1016/j.jiec.2011.02.004
11. Dey KP, Ghosh S, Naskar MK. Organic template-free synthesis of ZSM-5 zeolite particles using rice husk ash as silica source. *Ceramic International*. 2013;39(2): 2153–7. DOI:10.1016/j.ceramint.2012.07.083
12. Ban G, Song S, Lee HW, Kim HT. Effect of acidity levels and feed rate on the porosity of aerogel extracted from rice husk under ambient pressure. *Nanomaterials*. 2019;9(2). DOI:10.3390/nano9020300
13. Chen H, Wang W, Martin JC, Oliphant AJ, Doerr PA, Xu JF, et al. Extraction of lignocellulose and synthesis of porous silica nanoparticles from rice husks: A comprehensive utilization of rice husk biomass. *ACS Sustainable Chemistry and Engineering*. 2013;1(2):254–9. DOI:10.1021/sc300115r.
14. Singh LP, Bhattacharyya SK, Kumar R, Mishra G, Sharma U, Singh G, et al. Sol-Gel processing of silica nanoparticles and their applications. *Advances in Colloid and Interface Science*. Elsevier B.V. 2014;214:17–37. DOI:10.1016/j.cis.2014.10.007
15. Krishnarao RV, Subrahmanyam J, Jagadish Kumar T. Studies on the formation of black particles in rice husk silica ash. *Journal of European Ceramic Society*. 2001;21(1):99–104. DOI:10.1016/S0955-2219(00)00170-9.
16. Shahrokh Abadi MH, Delbari A, Fakoor Z, Baedi J. Effects of annealing temperature on infrared spectra of SiO<sub>2</sub> extracted from rice husk. *Journal of Ceramic Science and Technology*. 2015;6(1):41–5. DOI:10.4416/JCST2014-00028.
17. Ahmed AE, Adam F. Indium incorporated silica from rice husk and its catalytic activity. *Microporous and Mesoporous Materials*. 2007;103(1–3):284–95. DOI:10.1016/j.micromeso.2007.01.055.
18. Noushad M, Rahman IA, Husein A, Mohamad D, Ismail AR. A Simple Method of Obtaining Spherical Nanosilica from Rice Husk. *International Journal on Advanced Science, Engineering and Information Technology*. 2012;2(2):141. DOI:10.18517/ijaseit.2.2.172
19. Panpa W and Jinawath S. Synthesis of ZSM-5 zeolite and silicalite from rice husk ash. *Applied Catalysis B: Environmental*. 2009;90:389–394. DOI:10.1016/j.apcatb.2009.03029
20. Review (2007)-RHA-Properties & Its Uses (Comparison of chemical properties of RHA from diff countries).
21. Shahrokh Abadi MH, Delbari A, Fakoor Z, Baedi J. Effects of annealing temperature on infrared spectra of SiO<sub>2</sub> extracted from rice husk. *Journal of Ceramic Science and Technology*. 2015;6(1):41–5. DOI:10.4416/JCST2014-00028
22. Todkar BS, Deorukhkar OA, Deshmukh SM. Extraction of Silica from Rice Husk [Internet]. Vol. 12, *International Journal of Engineering Research*. 2016. Available: [www.ijerd.com](http://www.ijerd.com)
23. James J, Rao MS. silica from rice husk through thermal decomposition. *Thermochimica Acta*. 1986;97.
24. Patel KG, Shettigar RR, Misra NM. Recent Advance in Silica Production Technologies from Agricultural Waste Stream–Review. *Journal of Advanced Agricultural Technologies [Internet]*. 2017;4(3):274–9. DOI:10.18178/joaat.4.3.274-279.
25. Azat S, Sartova Z, Bekseitova K, Askaruly K. Extraction of high-purity silica from rice husk via hydrochloric acid leaching treatment. *Turkish Journal of Chemistry*. 2019;43(5):1258–1269. DOI:10.3906/kim-1903-53.
26. Bogeshwaran K, Kalaivani R, Ashraf S, Manikandan GN, Prabhu GE. Production of silica from rice husk [Internet]. Vol. 6, *Recent Trends in Biotechnology and Chemical Engineering*. 2014. Available:<https://www.researchgate.net/publication/285026933>
27. Ghorbani F, Sanati AM, Maleki M. Production of Silica Nanoparticles from Rice Husk as Agricultural Waste by Environmental Friendly Technique.

- Environmental Studies of Persian Gulf. 2015;2(1):56-65.
28. Della VP, Kühn I, Hotza D. Rice husk ash as an alternate source for active silica production. *Materials Letters*. 2002;57:818–821. [Internet]. Available: [www.elsevier.com/locate/matlet](http://www.elsevier.com/locate/matlet)
  29. Samuel Owoeye S. Effects of Extraction Temperature and Time on the Physical Properties of Soluble Sodium Silicate from Rice Husk Ash. *Science Journal of Chemistry*. 2017;5(1):8. DOI:10.11648/j.sjc.20170501.12.
  30. Huang S, Jing S, Wang J, Wang Z, Jin Y. Silica white obtained from rice husk in a fluidized bed [Internet]. *Powder Technology*. 2001;117. Available from: [www.elsevier.com/locate/powtec](http://www.elsevier.com/locate/powtec)
  31. Sarangi M, Nayak P, Tiwari TN. Effect of temperature on nano-crystalline silica and carbon composites obtained from rice-husk ash. *Compos B Eng*. 2011;42(7):1994–8. DOI:10.1016/j.compositesb.2011.05.026.
  32. Patil R, Dongre R, Meshram J. Preparation of Silica Powder from Rice Husk [Internet]. *IOSR Journal of Applied Chemistry (IOSR-JAC. Journal of Applied Chemistry*. 2014;26-29. Available: [www.iosrjournals.org](http://www.iosrjournals.org)
  33. Sankar S, Sharma SK, Kaur N, Lee B, Kim DY, Lee S, et al. Biogenerated silica nanoparticles synthesized from sticky, red, and brown rice husk ashes by a chemical method. *Ceramic International*. 2016;42(4):4875–85. DOI:10.1016/j.ceramint.2015.11.172.
  34. Conradt R, Pimkhaokham P, Leela-Adisorn U. Nano-structured silica from rice husk, *Journal of Non-Crystalline Solids*. 1992;45:75-79.
  35. Faé Gomes GM, Philipssen C, Bard EK, Zen LD, de Souza G. Rice husk bubbling fluidized bed combustion for amorphous silica synthesis. *Journal of Environmental Chemical Engineering*. 2016;4(2):2278–90. DOI:10.1016/j.jece.2016.03.049.
  36. Rozainee M, Ngo SP, Salema AA, Tan KG. Fluidized bed combustion of rice husk to produce amorphous siliceous ash. *Energy for Sustainable Development*. 2008;12(1):33–42. DOI:10.1016/S0973-0826(08)60417-2.
  37. Chakraverty A, Mishra P, Banerjee HD. Investigation of combustion of raw and acid-leached rice husk for production of pure amorphous white silica. *Journal of materials science*. 1988;23:21-24.
  38. Chandrasekhar S, Pramada PN, Praveen L. Effect of organic acid treatment on the properties of rice husk silica. *Journal of Materials Science*. 2005;40(24):6535–44. DOI:10.1007/s10853-005-1816-z.
  39. Chun J, Mo Gu Y, Hwang J, Oh KK, Lee JH. Synthesis of ordered mesoporous silica with various pore structures using high-purity silica extracted from rice husk. *Journal of Industrial and Engineering Chemistry*. 2020;81:135–43. DOI:10.1016/j.jiec.2019.08.064.
  40. An D, Guo Y, Zou B, Zhu Y, Wang Z. A study on the consecutive preparation of silica powders and active carbon from rice husk ash. *Biomass Bioenergy*. 2011;35(3):1227–34. DOI:10.1016/j.biombioe.2010.12.014.
  41. Adam F, Chua JH. The adsorption of palmytic acid on rice husk ash chemically modified with Al(III) ion using the sol-gel technique. *Journal of Colloid and Interface Science*. 2004;280(1): 55–61. DOI:10.1016/j.jcis.2004.07.006.
  42. Carmona VB, Oliveira RM, Silva WTL, Mattoso LHC, Marconcini JM. Nanosilica from rice husk: Extraction and characterization. *Industrial Crops and Products*. 2013;43(1):291–6. DOI:10.1016/j.indcrop.2012.06.050.
  43. Song S, Cho HB, Kim HT. Surfactant-free synthesis of high surface area silica nanoparticles derived from rice husks by employing the Taguchi approach. *Journal of Industrial and Engineering Chemistry*. 2018;61:281–7. DOI:10.1016/j.jiec.2017.12.025.
  44. Panasenko AE, Gerasimenko A v., Sloboduk AB, Dmitrenok PS, Didenko NA, Shapkin NP. Silicon Complexes from Rice Husk: Synthesis, Crystal Structure, and Properties of 1,2-bis-Silatranxyloxyethane. *Silicon*. 2019;11(2):1099–105. DOI:10.1007/s12633-018-9898-9.
  45. Le VH, Thuc CNH, Thuc HH. Synthesis of silica nanoparticles from Vietnamese rice husk by sol–gel method. *Nanoscale Research Letters*. 2013;8(1). DOI:10.1186/1556-276x-8-58.
  46. Rama R, Sivakumar G. Extraction, synthesis and characterization of nanosilica from rice husk ash Preparation of Bifunctional CuWO4-Based Heterostructure Nanocomposites for

- Noble-Metal-Free Photocatalysts View project Hydroxide based supercapacitors View project Amutha Kasinathan [Internet]. International Journal of Nanotechnology and Applications. 2010;4(1):61-66. Available:https://www.researchgate.net/publication/288893202
47. Nehdi M, Duquette J, El Damatty A. Performance of rice husk ash produced using a new technology as a mineral admixture in concrete. *Cement and Concrete Research*. 2003;33(8):1203 – 1210.
  48. Raheem AA, Kareem MA. Chemical composition and physical characteristics of rice husk ash blended cement. *International Journal of Engineering Research in Africa*. 2017;32:25–35. DOI:10.4028/www.scientific.net/JERA.32.2 5.
  49. Faizul CP, Abdullah C, Fazlul B. Review of extraction of silica from agricultural wastes using acid leaching treatment. In: *Advanced Materials Research*. 2013;997–1000. DOI:10.4028/www.scientific.net/AMR.626. 997.
  50. Chandrasekhar S, Satyanarayana KG, Pramada PN, Raghavan P, Gupta TN. Review Processing, properties and applications of reactive silica from rice husk-an overview. *Journal of materials science*. 2003;38:3159-3168.
  51. Geetha D. Preparation and Characterization of Silica Material from Rice Husk Ash – An Economically Viable Method. *Journal of Pure and Applied Physics*. 2016;4:20-26.
  52. Vlaev L, Petkov P, Dimitrov A, Genieva S. Cleanup of water polluted with crude oil or diesel fuel using rice husks ash. *Journal of the Taiwan Institute of Chemical Engineers*. 2011;42(6): 957–64. DOI:10.1016/j.jtice.2011.04.004.
  53. Liu Y, Guo Y, Zhu Y, An D, Gao W, Wang Z, et al. A sustainable route for the preparation of activated carbon and silica from rice husk ash. *Journal of Hazardous Materials*. 2011;186(2–3):1314–9. DOI:10.1016/j.jhazmat.2010.12.007.
  54. Thuadaij N, Nuntiya A. Synthesis and Characterization of Nanosilica from Rice Husk Ash Prepared by Precipitation Method. *Journal of natural sciences*. 2008;7(1).
  55. Ali M, Tindyala MA. Thermoanalytical studies on acid-treated rice husk and production of some silicon based ceramics from carbonised rice husk. *Journal of Asian Ceramic Societies*. 2015;3(3):311–6. DOI:10.1016/j.jascer.2015.06.003.
  56. Kaviyarasu K, Manikandan E, Kennedy J, Jayachandran M, Maaza M. Rice husks as a sustainable source of high quality nanostructured silica for high performance Li-ion battery requital by sol-gel method - a review. *Advanced Materials Letters*. 2016;7(9):684–96. DOI:10.5185/amlett.2016.6192.
  57. Ma X, Zhou B, Gao W, Qu Y, Wang L, Wang Z, et al. A recyclable method for production of pure silica from rice hull ash. *Powder Technology*. 2012;217:497–501. DOI:10.1016/j.powtec.2011.11.009.
  58. Kumar A, Singha S, Dasgupta D, Datta S, Mandal T. Simultaneous recovery of silica and treatment of rice mill wastewater using rice husk ash: An economic approach. *Ecological Engineering*. 2015; 84:29–37. DOI:10.1016/j.ecoleng.2015.07.010
  59. Ullah Z, Man Z, Khan AS, Muhammad N, Mahmood H, Ben Ghanem O, et al. Extraction of valuable chemicals from sustainable rice husk waste using ultrasonic assisted ionic liquids technology. *Journal of Cleaner Production*. 2019;220:620–9. DOI:10.1016/j.jclepro.2019.02.041.
  60. Mansha M, Javed SH, Kazmi M, Feroze N. Study of Rice Husk Ash as Potential Source of Acid Resistance Calcium Silicate. *Advances in Chemical Engineering and Science*. 2011;01(03):147–53. DOI:10.4236/aces.2011.13022.
  61. Sekifuji R, Le V, Liyanage B, Tateda M. Observation of Physio-Chemical Differences of Rice Husk Silica under Different Calcination Temperatures. *Journal of Scientific Research and Reports*. 2017;16(6):1–11. DOI:10.9734/jsrr/2017/37621.
  62. Bakar RA, Yahya R, Gan SN. Production of High Purity Amorphous Silica from Rice Husk. *Procedia Chemistry*. *Procedia Chemistry*. 2016;19:189–95. DOI:10.1016/j.proche.2016.03.092.
  63. Qudratun, Kusumandari IY, Khoirum S. effect of sintering temperature on dielectric constant of silica prepared from rice husk ash [Internet]. Adopted from MEV Journal; 2012.

- Available: [www.mevjournal.com](http://www.mevjournal.com)
64. Haslina S, Rusmili A, Yuliati L, Ramli Z. Rapid synthesis and characterization of nanosodalite synthesized using rice husk ash (Sintesis Cepat dan Pencirian Nanosodalit yang Disintesis Menggunakan Abu Sekam Padi). *The Malaysian Journal of Analytical Sciences*. 2012;16.
  65. Zain MFM, Islam MN, Mahmud F, Jamil M. Production of rice husk ash for use in concrete as a supplementary cementitious material. *Construction and Building Materials*. 2011;25(2): 798–805. DOI:10.1016/j.conbuildmat.2010.07.003.
  66. Patil R, Dongre R, Meshram J. Preparation of Silica Powder from Rice Husk [Internet]. *IOSR Journal of Applied Chemistry (IOSR-JAC)*. 2014;26-29. Available: [www.iosrjournals.org](http://www.iosrjournals.org)
  67. Onojah AD, Agbendeh NA, Mbakaan C. Rice husk ash refractory: The temperature dependent crystalline phase aspects. *International Journal of Recent Research and Applied Studies*. 2013;15. Available: [www.arpapress.com/Volumes/Vol15Issue2/JRRAS\\_15\\_2\\_12.pdf](http://www.arpapress.com/Volumes/Vol15Issue2/JRRAS_15_2_12.pdf)
  68. Liu Y, Guo Y, Zhu Y, An D, Gao W, Wang Z, et al. A sustainable route for the preparation of activated carbon and silica from rice husk ash. *Journal of Hazardous Materials*. 2011;186(2–3):1314–9. DOI:10.1016/j.jhazmat.2010.12.007.
  69. Mezan SO, Absi SM Al, Jabbar AH, Roslan MS, Agam MA. Synthesis and characterization of enhanced silica nanoparticle (SiO<sub>2</sub>) prepared from rice husk ash immobilized of 3-(chloropropyl) triethoxysilane. In: *Materials Today: Proceedings*. Elsevier Ltd. 2021;2464–8. DOI:10.1016/j.matpr.2020.12.564.
  70. Sankar S, Sharma SK, Kaur N, Lee B, Kim DY, Lee S, et al. Biogenerated silica nanoparticles synthesized from sticky, red, and brown rice husk ashes by a chemical method. *Ceramics International*. 2016;42(4):4875–4885. DOI:10.1016/j.ceramint.2015.11.172.
  71. Mohammed A, Abdullah A. Scanning Electron Microscopy (SEM): A Review Strengthening beams View project Modeling Mechanical Behavior of Geopolymer concrete View project Scanning Electron Microscopy (SEM): A Review [Internet]. Available: <https://www.researchgate.net/publication/330168803>
  72. Krishnarao RV, Subrahmanyam J, Kumar TJ. Studies on the formation of black particles in rice husk silica ash. *Journal of the European Ceramic Society*. 2001;21:99-104. Available: [www.elsevier.com/locate/jeurceramsoc](http://www.elsevier.com/locate/jeurceramsoc)
  73. Abood Habeeb G, Bin Mahmud H. Study on Properties of Rice Husk Ash and Its Use as Cement Replacement Material. *Materials Research*. 2010;13(2):185-190.
  74. Bui LAT, Chen CT, Hwang CL, Wu WS. Effect of silica forms in rice husk ash on the properties of concrete. *International Journal of Minerals, Metallurgy and Materials*. 2012;19(3):252–8.
  75. Madrid R, Nogueira CA, Margarido f. Production and characterisation of amorphous silica from rice husk waste. *International Conference on Engineering for Waste and Biomass Valorisation*. 2012;
  76. Liou TH, Yang CC. Synthesis and surface characteristics of nano silica produced from alkali-extracted rice husk ash. *Materials Science and Engineering B: Solid-State Materials for Advanced Technology*. 2011;176(7):521–529. DOI:10.1016/j.mseb.2011.01.007
  77. Fernandes IJ, Calheiro D, Sánchez FAL, Camacho ALD, De Campos Rocha TLA, Moraes CAM, et al. Characterization of silica produced from rice husk ash: Comparison of purification and processing methods. In: *Materials Research*. Universidade Federal de Sao Carlos. 2017; 20:519–25. DOI:10.1590/1980-5373-mr-2016-1043
  78. Noushad M, Rahman IA, Husein A, Mohamad D, Ismail AR. A Simple Method of Obtaining Spherical Nanosilica from Rice Husk. *International Journal on Advanced Science, Engineering and Information Technology*. 2012;2(2):141. DOI:10.18517/ijaseit.2.2.172.
  79. Rukari T. Alhat B. Transmission electron microscopy- an overview. *International Research Journal for Inventions in Pharmaceutical Sciences*. 2013;1:1-7.
  80. Hello KM, Mohammed MJ, Yasser AM, Adam F, Farag Z. Modification of Silica Rice Husk Ash to Solid Ammonium Sulphate for Second Generation Biofuels Productions. *Journal of Catalysts*. 2014;2014:1–9.

- DOI:10.1155/2014/128547
81. Nassar EJ, audio Neri CR, Cale PS, Serra OA. Functionalized silica synthesized by sol-gel process. *Journal of Non-Crystalline Solids*. 1999;247:124-128.
  82. Ali MS, Hanim MAA, Tahir SM, Jaafar CNA, Mazlan N, Amin Matori K. The Effect of Commercial Rice Husk Ash Additives on the Porosity, Mechanical Properties, and Microstructure of Alumina Ceramics. *Advances in Materials Science and Engineering*; 2017. DOI:10.1155/2017/2586026.
  83. Lemessa Jembere A. Studies on the Synthesis of Silica Powder from Rice Husk Ash as Reinforcement Filler in Rubber Tire Tread Part: Replacement of Commercial Precipitated Silica. *International Journal of Materials Science and Applications*. 2017;6(1):37. DOI:10.11648/j.ijmsa.20170601.16.
  84. Zou Y, Yang T. Rice husk, rice husk ash and their applications. In: *Rice Bran and Rice Bran Oil: Chemistry, Processing and Utilization*. Elsevier. 2019:207–46. DOI:10.1016/B978-0-12-812828-2.00009-3
  85. Tadjarodi A, Haghverdi M, Mohammadi V. Preparation and characterization of nanoporous silica aerogel from rice husk ash by drying at atmospheric pressure. *Materials Research Bulletin*. 2012;47(9):2584–9. DOI:10.1016/j.materresbull.2012.04.143
  86. Boateng AA, Skeete DA. incineration of rice hull for use as a cementitious material: The guyana experience., *Cement and Concrete research*. 1990;20.
  87. Kestur S, Chandrasekhar S, Satyanarayana KG, Pramada PN, Raghavan P, Gupta TN. Review Processing, properties and applications of reactive silica from rice husk-an overview. *Journal of Materials Science*. 2003;38:3159-3168.
  88. Deshmukh P, Bhatt J, Peshwe D, Pathak S. Determination of Silica Activity Index and XRD, SEM and EDS Studies of Amorphous SiO<sub>2</sub> Extracted from Rice. *Transactions of the Indian Institute of Metals*. 2012;65(1):63–70. DOI:10.1007/s12666-011-0071-z
  89. Genieva SD, Ch Turmanova S, Dimitrova AS, Vlaev LT. Introduction characterization of rice husks and the products of its thermal degradation in air or nitrogen atmosphere. *Journal of Thermal Analysis and Calorimetry*. 2008;93(2):387–396.
  90. Chaudhary DS, Jollands MC. Characterization of rice hull ash. *Journal of Applied Polymer Science*. 2004;93(1):1–8. DOI:10.1002/app.20217
  91. Ge J, Huynh T, Hu Y, Yin Y. Hierarchical magnetite/silica nanoassemblies as magnetically recoverable catalyst-supports. *Nano Letters*. 2008;8(3):931–4. DOI:10.1021/nl080020f
  92. Adam F, Appaturi JN, Iqbal A. The utilization of rice husk silica as a catalyst: Review and recent progress. *Catalysis Today*. 2012;190(1):2–14. DOI:10.1016/j.cattod.2012.04.056
  93. Sobrosa FZ, Stochero NP, Marangon E, Tier MD. Development of refractory ceramics from residual silica derived from rice husk ash. *Ceramics International*. 2017;43(9):7142–6. DOI:10.1016/j.ceramint.2017.02.147
  94. Bakaev VA, Pantano CG. Inverse reaction chromatography. 2. hydrogen/deuterium exchange with silanol groups on the surface of fumed silica. *Journal of Physical Chemistry C*. 2009;113(31):13894–8. DOI:10.1021/jp810984r
  95. Raut BK, Panthi KP. Extraction of Silica Nanoparticles from Rice Husk Ash (RHA) and Study of Its Application in Making Composites. *Journal of Nepal Chemical Society*. 2019;40:67–72. DOI:10.3126/jncs.v40i0.27285.
  96. Marin DC, Vecchio A, Ludueña LN, Fasce D, Alvarez VA, Stefani PM. Revalorization of rice husk waste as a source of cellulose and silica. *Fibers and Polymers*. 2015;16(2):285–93. DOI:10.1007/s12221-015-0285-5.
  97. Subbukrishna DN, Suresh KC, Paul PJ, Dasappa S, Rajan NKS. precipitated silica from rice husk ash by ipsit process. *European Biomass Conference & Exhibition*. 2007.
  98. Patel KG, Shettigar RR, Misra NM. Recent Advance in Silica Production Technologies from Agricultural Waste Stream–Review. *Journal of Advanced Agricultural Technologies*. 2017; 4(3): 274–279. DOI:10.18178/joaat.4.3.274-279.
  99. Phule Krishi Vidyapeeth M, Durgude IA, Pharande I AL, Kadlag IA. AA Patil Department of Soil Science and Agricultural Chemistry. ~ 545 ~ *International Journal of Chemical Studies*. 2017;5(6):545–9.
  100. Frasetya B, Harisman K, Sudrajat D, Subandi M. Utilization of rice husk silicate

- extract to improve the productivity of paddy Ciharang cultivar. Vol. 25, Bulgarian Journal of Agricultural Science; 2019.
101. Rodrigo AS, Perera S. Electricity Generation Using Rice Husk in Sri Lanka: Potential and Viability Techno Economic Feasibility of Solar PV with Battery Energy Storage for Domestic Sector and EV Charging View project Designing the Load Shedding Scheme View project Electricity Generation Using Rice Husk in Sri Lanka: Potential and Viability [Internet]. 2014. Available:<https://www.researchgate.net/publication/268204278>.
102. Bernal SA, Rodríguez ED, Mejia De Gutiérrez R, Provis JL, Delvasto S. Activation of metakaolin/slag blends using alkaline solutions based on chemically modified silica fume and rice husk ash. Waste Biomass Valorization. 2012;3(1):99–108. DOI:10.1007/s12649-011-9093-3.
103. Saxena RC, Seal D, Kumar S, Goyal HB. Thermo-chemical routes for hydrogen rich gas from biomass: A review. Vol. 12, Renewable and Sustainable Energy Reviews. 2008;1909–27. DOI:10.1016/j.rser.2007.03.005
104. Russell LM, Johnson LF, Haselman DPH, Ruh R. Thermal Conductivity/Diffusivity of Silicon Carbide Whisker Reinforced Mullite. Communications of the American Ceramic Society. 1987;70(10): 226-229.
105. Soltani N, Bahrami A, Pech-Canul MI, González LA. Review on the physicochemical treatments of rice husk for production of advanced materials. Chemical Engineering Journal. Elsevier. 2015;264:899–935. DOI: 10.1016/j.cej.2014.11.056.
106. Sun L, Gong K. Silicon-based materials from rice husks and their applications. Industrial and Engineering Chemistry Research. American Chemical Society. 2001;40:5861–77. DOI:10.1021/ie010284b.
107. Islam SM, Hussain RR, Morshed MAZ. Fiber-reinforced concrete incorporating locally available natural fibers in normal- and high-strength concrete and a performance analysis with steel fiber-reinforced composite concrete. Journal of Composite Materials. 2012;46(1):111–22. DOI:10.1177/0021998311410492.
108. Paya J, Monzo J, Borrachero M V, Mellado A, Ordonñez LM. Determination of amorphous silica in rice husk ash by a rapid analytical method. Cement and Concrete Research. 2001;31:227-231.

© Copyright (2024): Author(s). The licensee is the journal publisher. This is an Open Access article distributed under the terms of the Creative Commons Attribution License (<http://creativecommons.org/licenses/by/4.0>), which permits unrestricted use, distribution, and reproduction in any medium, provided the original work is properly cited.

*Peer-review history:*

*The peer review history for this paper can be accessed here:*  
<https://www.sdiarticle5.com/review-history/113971>